

HM

HM Series / HM-M Series

HIGH-PERFORMANCE HOT CHAMBER
DIE CASTING MACHINE



Yizumi Holdings Co., Ltd.

Address: No.22 Ke Yuan 3rd Road, Shunde, Foshan, Guangdong 528300, China
TEL: 86-757-2926 5301 86-757-2926 5300(overseas) Email: dcsolutions@yizumi.com
www.yizumi.com

[DISCLAIMER]

- [1] YIZUMI reserves the right to modify the product description in the catalogue. Specification might be changed without prior notice.
- [2] The picture in the catalogue is for reference only. The real object should be considered as final.
- [3] The data in the catalogue is obtained from internal testing in YIZUMI laboratory.
Please refer to the actual machine for the final data. YIZUMI reserves the right of final interpretation upon disputes and ambiguities.



THINK TECH FORWARD

HM Series Hot Chamber Die Casting Machine (For Zinc Alloy)

HM series hot chamber die casting machine focuses on high-quality production, which has become the most efficient machine in YIZUMI hot chamber series. It has been widely applied in 3C, bathroom, clothes, hardware and house furnishing fields.

Three Most Valuable Advantages

Outstanding performance

| Better Performance

100% focus on high quality production. An optimized injection system ensures an accurate and stable injection process.

| More Efficient

The YIZUMI high speed toggle system provides highest manufacturing productivity with shortest cycle times.

| Easier Operation

Siemens PLC control system with the high-end human-machine-interface offers time saving process setting with high convenience and flexibility.



HM

Better Performance

Ensuring a highly efficient, accurate and stable injection process.



High Efficiency

Fast Sensitive Control

Dry injection speed $\geq 5\text{m/s}$, pressure and flow are controlled by a proportional valve and parameters can be set on the screen to save time in process setting.



Automatic Sprayer

Reliable and durable automatic sprayer ensures fast and stable production.



High Precision

Highly Precise Injection

The optimized injection system with two stage injection control is suitable for high-quality productions.



Highly Precise Clamping

High precision imported stroke transducer allows for precise and repeatable opening and closing.



Stable Performance

Advanced Electronic Heating System

Equipped with advanced nozzle/gooseneck heating control system.



Nozzle Temperature Gooseneck Temperature Furnace Temperature

Burner

Energy-saving system with smart controller and world-class burner, offers stable heating and easy adjustment functions.



Higher Efficiency

Stable high-speed clamping offers higher production efficiency.



Vickers' hydraulic components ensure stable and productive operation.

High-speed Clamping

Optional high-speed clamping system shortens cycle times to reach a higher OEE in the casting production.



Stable Clamping

Enhanced ductile cast iron platen with highest rigidity protects the die casting die and reduces flash. Chromium plated high strength steel tie bars with extended service life.



Easier to operate

Easy to understand operator panel.



Powerful automatic alarm system provides quick trouble-shooting support.

The control screen is equipped with a safety interlock. Further features include functions such as fault diagnostics and display and production management, and data storage increasing operational efficiency.



Visual setting and operation interface

Smart PLC control system with intelligent human-machine interface offers fast and time saving process setting. Convenient "on-screen" programming of a large variety of functions further enhances operation.



Specifications— HM Series

ITEM	Unit	HM90	HM160	HM200	HM280	HM400
Die Locking Force	kN	800	1600	2000	2800	4000
Die Locking Stroke	mm	280	350	400	460	550
Die Height (Min.-Max.)	mm	150-360	205-505	250-550	250-650	300-750
Tie-Bar Space (HXV)	mm	357X357	459X459	510X510	560X560	650X650
Ejector Force	kN	50	108	108	158	180
Ejector Stroke	mm	60	85	100	100	120
Shot Force	kN	65	108	130	158	182
Shot Stroke	mm	130	150	175	200	230
Plunger Diameter	mm	45,50,60	60,65,70	60,65,70	70,80	70,80,90
Injection Weight(Zn)	kg	1,1.3,1.5	2.1,2.5,2.9	2.5,2.9,3.3	3.8,5	4.4,5.7,7.2
Casting Pressure	MPa	40.8,33,27	38.2,33,28	46,39,34	41,31.4	47,36,29
Casting Area	cm ²	193-296	418-571	434-593	682-891	845-1399
Shot Position	mm	0	0,-80	0,-100	0,-125	0,-125
Engagement Stroke	mm	190	200	200	200	340
Crucible Capacity	dm ³	50	55	110	110	200
	kg/Zn	330	360	720	720	1350
Fuel Furnace	kg/h	4.8	4.8	6.3	6.3	11.2
Electrical Furnace	kW	30	42	65	65	90
Standard Heater for Nozzle	kW	2	2.5	4	5	5
Working Pressure	MPa	10.5	14	14	14	14
Motor Capacity	kW	11	15	15	18.5	22
Hydraulic Oil Tank Capacity	L	250	300	400	500	800
Machine Dimension(LxWxH)	mm	4370X1620 X2120	5550X1630 X2580	5950X1750 X2600	6500X1850 X2650	7500X2250 X2950

■ Option ■ Remark: The Data above were acquired by testing in the factory, only for your reference.
The specific data please accord to the actual equipment.

Standard & Optional Features – HM Series

ITEM	HM90	HM160	HM200	HM280	HM400
Cooling water on fix platen	●	●	●	●	●
Auto spray nozzle 1 set	●	○	○	○	○
Knocking cylinder	●	○	○	○	○
Core pulling 1 set	●	●	●	●	●
Extra core pulling device	○	○	○	○	○
Core limit switch 2 sets	●	●	●	●	●
"0" shot position	●	●	●	●	●
Special shot position	○	○	○	○	○
Hydraulic lifter (two shot position)	○	●	●	●	●
Electrical safety door (left)	○	○	●	●	●
Electrical safety door (right)	○	○	○	○	○
Diesel Burner	●	●	●	●	●
Gas Burner	○	○	○	○	○
Electrical melting furnace	○	○	○	○	○
Clamping force display	○	○	○	○	○
Automatic die change device	○	○	○	○	○
Shot curve display and monitor	○	○	○	○	○

●Standard ○Optional

HM-M Series Hot Chamber Die Casting Machine (For Magnesium)

HM200M-HM400M

High efficiency production solution for precision thin-wall magnesium alloy parts.

For many years now YIZUMI provides the casting industry with highly productive Mg-Hot-Chamber-Casting solutions.

- An enhanced hydraulic control system ensures stable production with minimum reject.
- With the use of a well proven electronic control system we ensure highest operational reliability
- An optimized HMI ensures easy and time saving programming for the operators.
- Enhancements on the toggle geometry as well as the sprue-break-cylinder increased productivity & cycle time.

Application Fields

HM-M Series Hot Chamber Magnesium Alloy Die Casting Machine is suitable for the production processes of precise and complex magnesium alloy die cast parts.

Its main application lies in extra thin-wall magnesium alloy parts (wall thickness < 1mm), such as mobile phone cases, tablet computers and other 3C product applications



Tablet PC Board



Laptop Casing



Computer accessories



Phone medium plate



E-book accessories



HM-M Series offers international technology solutions for competitive Magnesium Alloy Die Casting

HM-M



Higher Efficiency

A clamping system up to 10% faster than comparable machines offers productivity benefits to our customers.



Accurate Control

A high-quality and low-noise hydraulic pump, offers increased machine performance while reducing energy consumption. Pressure and flow are controlled by a proportional valve; the parameters can be set on the screen which improves accuracy.



Higher Stability

Enhanced ductile cast iron platen with highest rigidity protects the die casting die and reduces flash



Unique Design of Accumulate System

A highly stable high-capacity accumulator system with wide cross sections ensures a highly stable and repeatable injection performance.



High Configuration

Equipped with automatic safety gate which is fast, accurate and stable.



Optimized human-machine integration

Our well structured and easy to understand operator panel eases operation of the HM machine and enhances overall productivity.



Specifications – HM-M Series

ITEM	Unit	HM200M	HM280M	HM400M
Die Locking Force	kN	2000	2800	4000
Die Locking Stroke	mm	400	460	550
Die Height (Min.-Max.)	mm	250-550	250-650	300-750
Tie-Bar Space (HXV)	mm	510X510	560X560	650X650
Ejector Force	kN	108	158	180
Ejector Stroke	mm	100	100	120
Shot Force	kN	130	158	182
Shot Stroke	mm	175	230	230
Plunger Diameter	mm	70,80	70,80	80,90
Injection Weight (Mg)	kg	0.78, 1.03	1.03, 1.35	1.35, 1.71
Casting Pressure	MPa	33.7, 25,8	41, 31.4	36.8, 29
Casting Area	cm ²	473, 618	545, 712	868, 1103
Shot Position	mm	0, -100	0, -125	0, -125
Engagement Stroke	mm	275	340	340
Working Pressure	MPa	14	14	14
Motor Capacity	kW	15	18.5	22
Hydraulic Oil Tank Capacity	L	400	500	800
Machine Dimension(L×W×H)	mm	5950X1750X2600	6500X1850X2650	7500X2250X2950

■ Option ■ Remark: The Data above were acquired by testing in the factory, only for your reference.
The specific data please accord to the actual equipment.

Standard & Optional Features – HM-M Series

ITEM	HM200M	HM280M	HM400M
Die close proportional control	●	●	●
Low-pressure die close protection function	●	●	●
Central lubrication device	●	●	●
Hydraulic die height adjustment	●	●	●
PLC and touch screen	●	●	●
Independent electrical cabinet	●	●	●
Movable control panel	●	●	●
Electrical safety door (left)	●	●	●
Electrical safety door (right)	○	○	○
Hydraulic disengagement	●	●	●
Hydraulic lifter (two shot positions)	●	●	●
Hydraulic ejector	●	●	●
Core pulling 1 set	●	●	●
Clamping force display	○	○	○
Automatic die change device	○	○	○
Injection monitoring and curve display	○	○	○

●Standard ○Optional

Platen Dimensions & Layout

– HM(M) Series

HM90

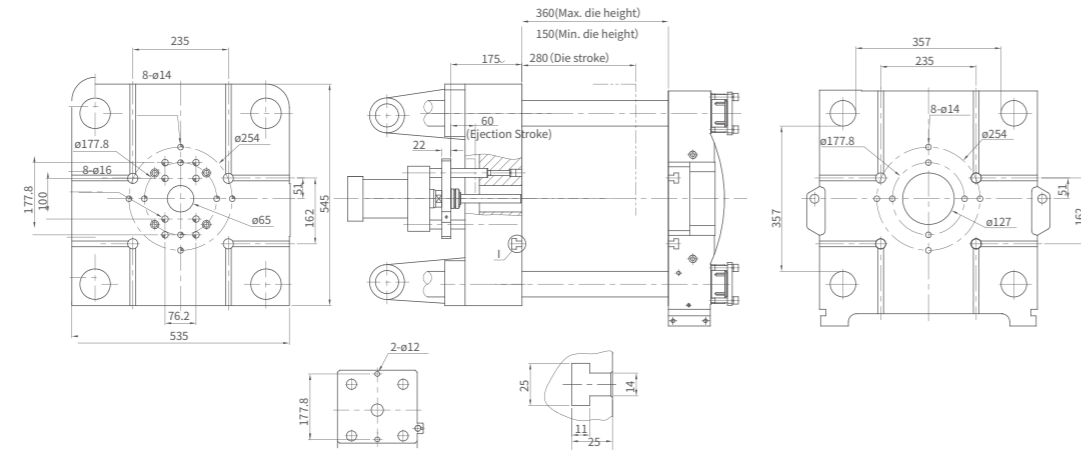

HM280(M)

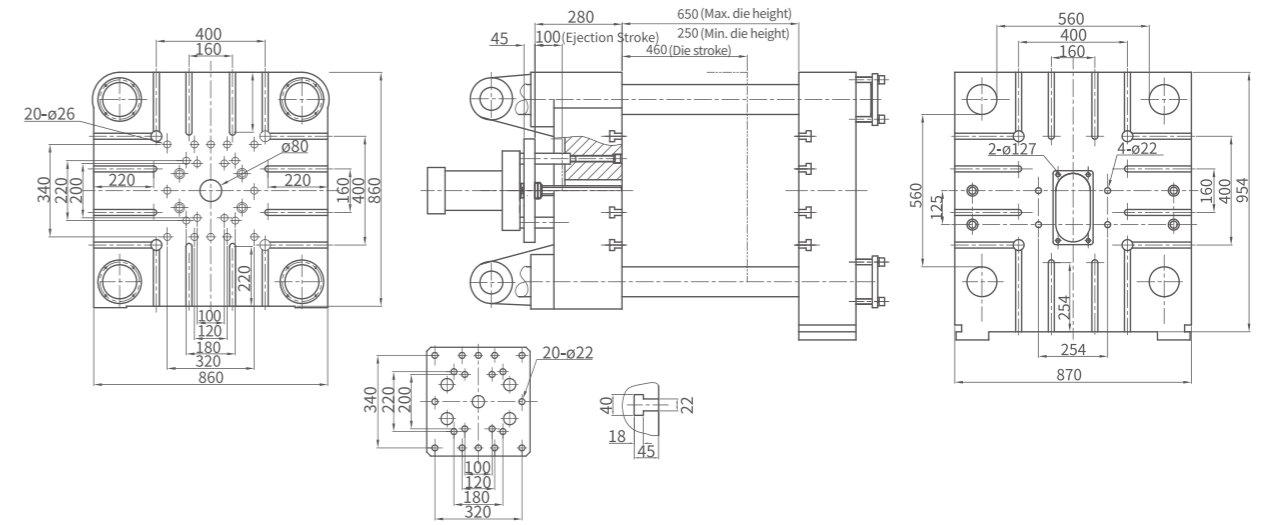

HM160

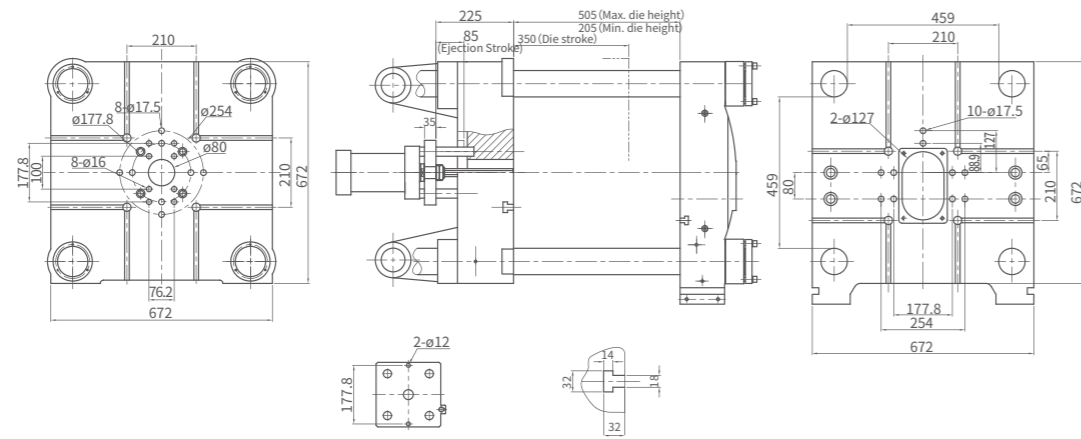

HM400(M)

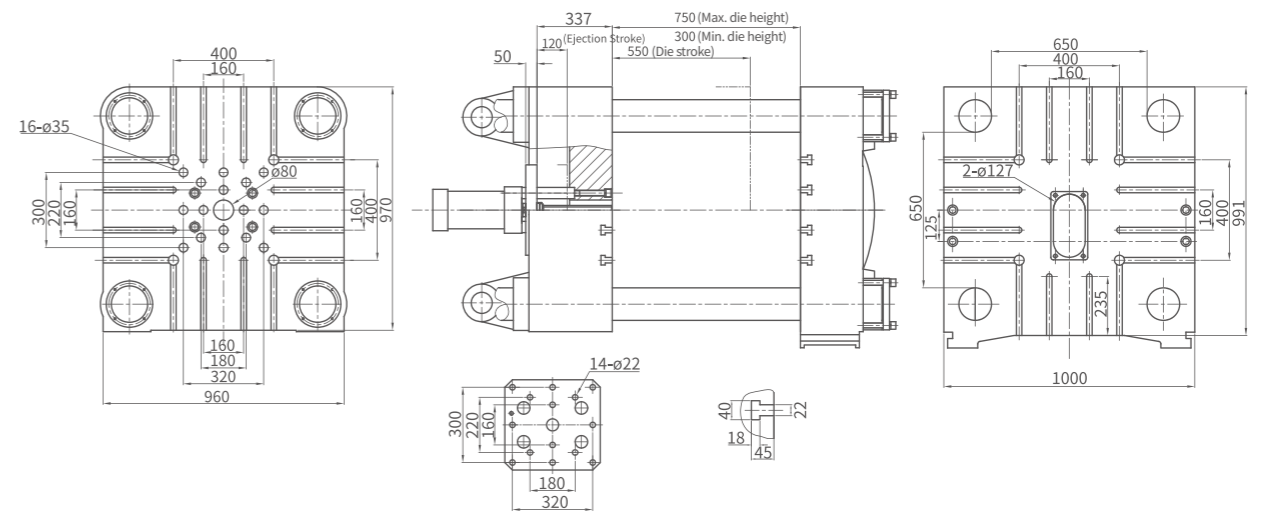

HM200(M)

